



SINCE 1967

Specification

機種 Description	單位 mm	CDM-2000SD	CDM-3000SD	CDM-4000D	CDM-5000D	CDM-6000D	
加工容量 Capacity	工作台行程 (X軸) Table Travel (X axis)	mm	2000	3000	4000	5000	6000
	主軸行程 (Y軸) Rail Head Travel (Yaxis)	mm	1200	1800	2500	2500	2500
	滑道行程 (Z軸) Head Slide Travel (Z axis)	mm	750	750	950	950	950
	主軸鼻端至工作台面距離 Height From Spindle Nose To Table	mm	80-830	80-830	200-1150	200-1150	200-1150
	兩柱間距 Distance Between Columns	mm	1400	2000	2700	2700	2700
	硬軌型式 Slideway Type		XYZ Square Box Slideway (XYZ方型硬軌)				
			Y Stairway (Y軸階梯式)				
工作台 Work Table	工作台面積 (L×W) Working Area	mm	2100 × 1000	3100 × 1500	4100 × 2000	5100 × 2000	6100 × 2000
	地面至工作台面距離 Height From Floor To Table Surface	mm	670	830	930	930	930
	工作台T型槽 T-Slot	mm×No.	22 × 7	22 × 9	24 × 11	24 × 11	24 × 11
主軸 Spindle	主軸錐度 Spindle Taper		MAS403 BT-50	MAS403 BT-50	MAS403 BT-50	MAS403 BT-50	MAS403 BT-50
	拉刀螺絲 Pull-Stud		MAS403 P50T-1	MAS403 P50T-1	MAS403 P50T-1	MAS403 P50T-1	MAS403 P50T-1
	主軸段數 Spindle Change		High / Low Gear Stepless (高低檔無段變速)				
	主軸轉速 Spindle Speed	r.p.m.	40-6000	40-6000	40-6000	40-6000	40-6000
速度 Speed	工作台切削速度 (X軸) Table Speed (X axis)	mm/min	1-5000	1-5000	1-5000	1-5000	1-5000
	工作台進給速度 (X軸) Table Rapid Speed (X axis)	mm/min	12000	12000	10000	10000	10000
	主軸頭切削速度 (Y軸) Rail Head Speed (Y axis)	mm/min	1-5000	1-5000	1-5000	1-5000	1-5000
	主軸頭進給速度 (Y軸) Rail Head Rapid Feed Speed (Y axis)	mm/min	12000	12000	10000	10000	10000
	滑枕切削速度 (Z軸) Head Slide Speed (Z axis)	mm/min	1-5000	1-5000	1-5000	1-5000	1-5000
	滑枕進給速度 (Z軸) Head Slide Elevation Rapid Speed (Z axis)	mm/min	12000	12000	10000	10000	10000
精度標準 Accuracy	最小輸入單位 Least Input Increment	mm	0.001	0.001	0.001	0.001	0.001
	定位精度 Positioning Accuracy	mm	±0.025 / Full travel	±0.025 / Full travel	±0.03 / Full travel	±0.03 / Full travel	±0.03 / Full travel
	重複定位精度 Repeatability Accuracy	mm	±0.01	±0.01	±0.01	±0.01	±0.01
刀庫 ATC	刀庫容量 ATC Capacity		40把	40把	40把	40把	40把
	刀具選擇方式 Tool Changing System		Bi-Direction Tool Changing (雙向捷徑選刀)				
	最大刀具長度 Max. Tool Length	mm	400	400	400	400	400
	最大刀具直徑 Max. Tool Diameter		Ø125 (Ø250)	Ø125 (Ø250)	Ø125 (Ø250)	Ø125 (Ø250)	Ø125 (Ø250)
	最大刀具重量 Max. Tool Weight	kg	18	18	18	18	18
馬達 Motor	主軸馬達 (連續30分鐘) Spindle Motor (30min/cont.)	Kw	Fanuc AC 15 / 18 AC 12 / 16	Siemens AC 15 / 18 AC 12 / 16	AC 22 / 26 AC 22 / 30	AC 22 / 26 AC 22 / 30	AC 22 / 26 AC 22 / 30
機械重量 Machine Weight		kg	16000	26000	47000	52800	58600
機械佔用面積 (L×w×h) Required Floor Space		mm	6000×3400×3600	8100×4000×3900	11200×5100×4720	13200×5100×4720	15200×5100×4720
機械工作台承載重量 Max. Loading Weight		kg	6800	9000	12800	13800	15000
連接電力 Power			55 KVA	55 KVA	55 KVA	55 KVA	55 KVA
NC裝置 Controller			FANUC 0i、18i系列		SIEMENS 810D、840D系列		

* 由於不斷的研究發展改進，規格設計如有變更，恕不另行通知。

Due to constant researches, development, improvement, all specifications and designs are subject to change without notice.



SINCE 1967

CNC 門型綜合加工中心機 CNC Machining Center

CDM-2000SD · 3000SD
CDM-4000D · 5000D · 6000D



張圳雄企業股份有限公司
CHANG CHUN HSIUNG ENTERPRISE CO., LTD.
台中市太平區永義路113號
113, YUNG YI ROAD, TAIPING DIST., TAICHUNG
CITY, TAIWAN
TEL : 886-4-22733363 · 886-4-22733665
FAX : 886-4-22733369
E-mail : changccb@ms36.hinet.net
Web : www.topchang.com.tw



CNC 門型綜合加工中心機 CNC Machining Center CDM-2000SD · 3000SD · 4000D · 5000D · 6000D



高強度主軸頭 High Strength Spindle
適用強力切削，如 銑切，精密塘孔，鑽孔，攻牙。
Suitable for heavy-cutting, Precision boring, drilling and tapping.

主軸輸出與轉矩
Spindle output and torque

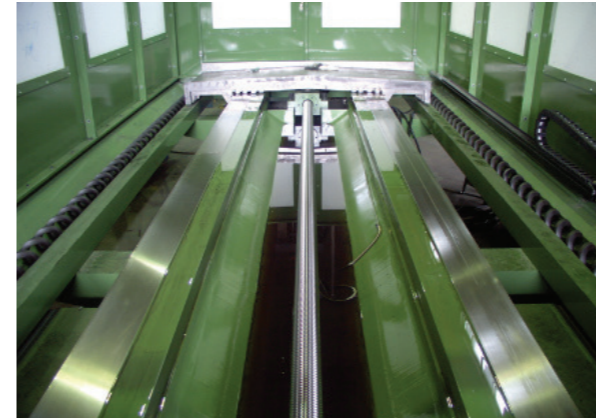
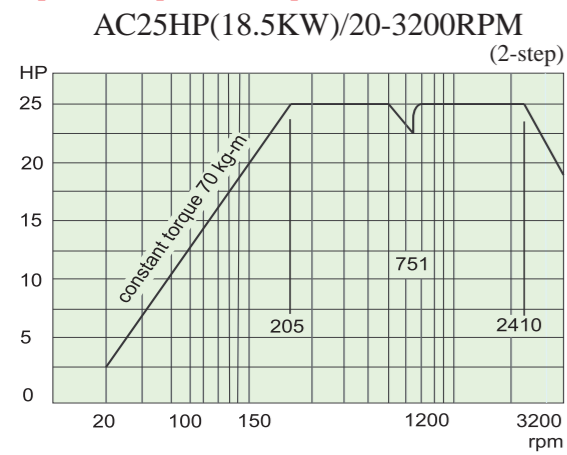

完美的切削清除設計 Perfect chip cleaning design. The spiral and efficient design of the chip conveyor delivers the chips to the conveyor chain.



快速及強力的ATC系統
刀庫一般容納40把刀，可依需求增加，刀具換刀時間12秒。

Powerful and Fast tool changing capabilities. Standard 40 piece tool holder. Additional tooling set ups are available. Tool change time is about 12 seconds.

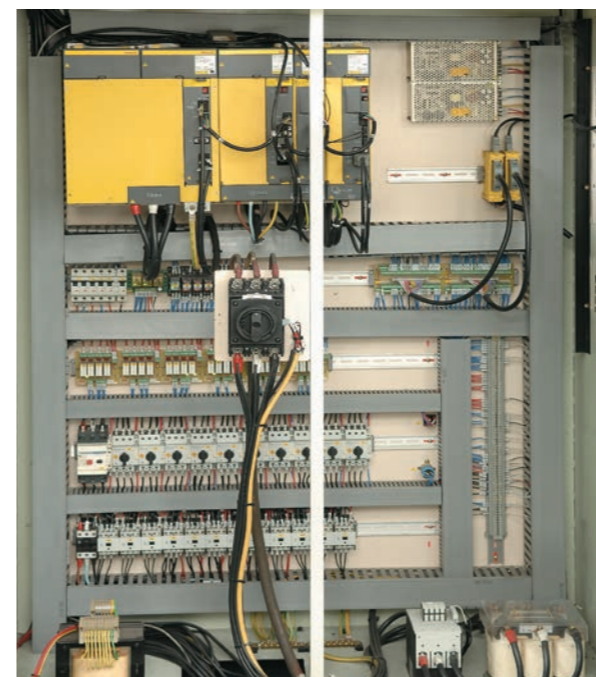

機器外觀尺寸 Machine Size

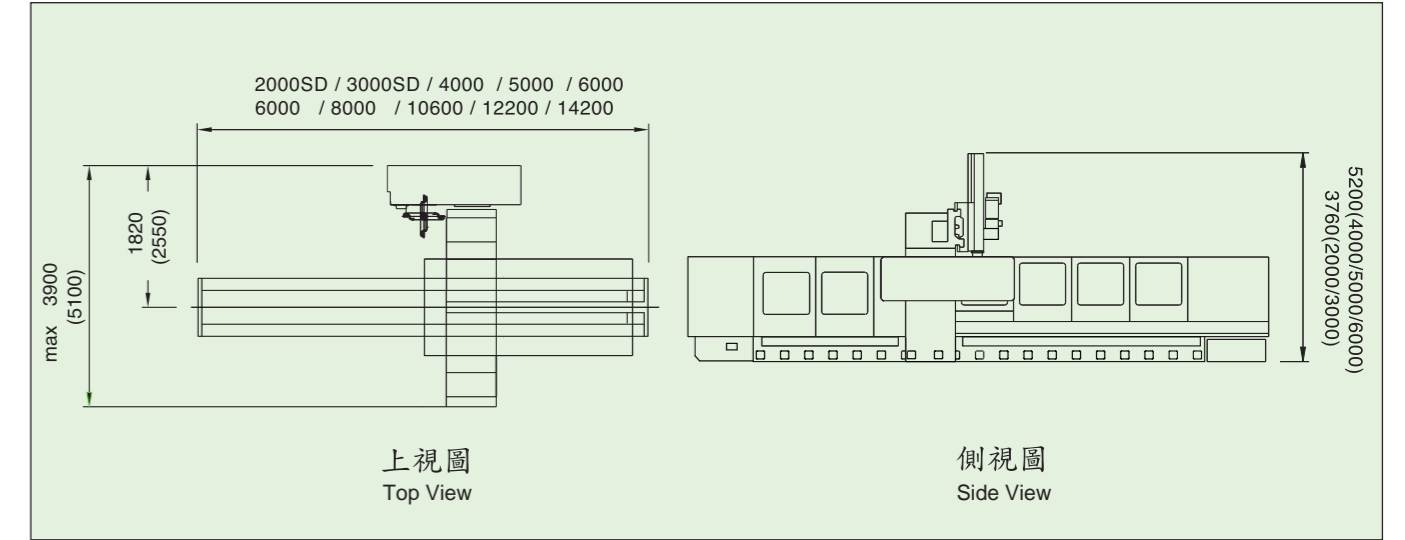

工作台 T型槽 Table, T-Slot

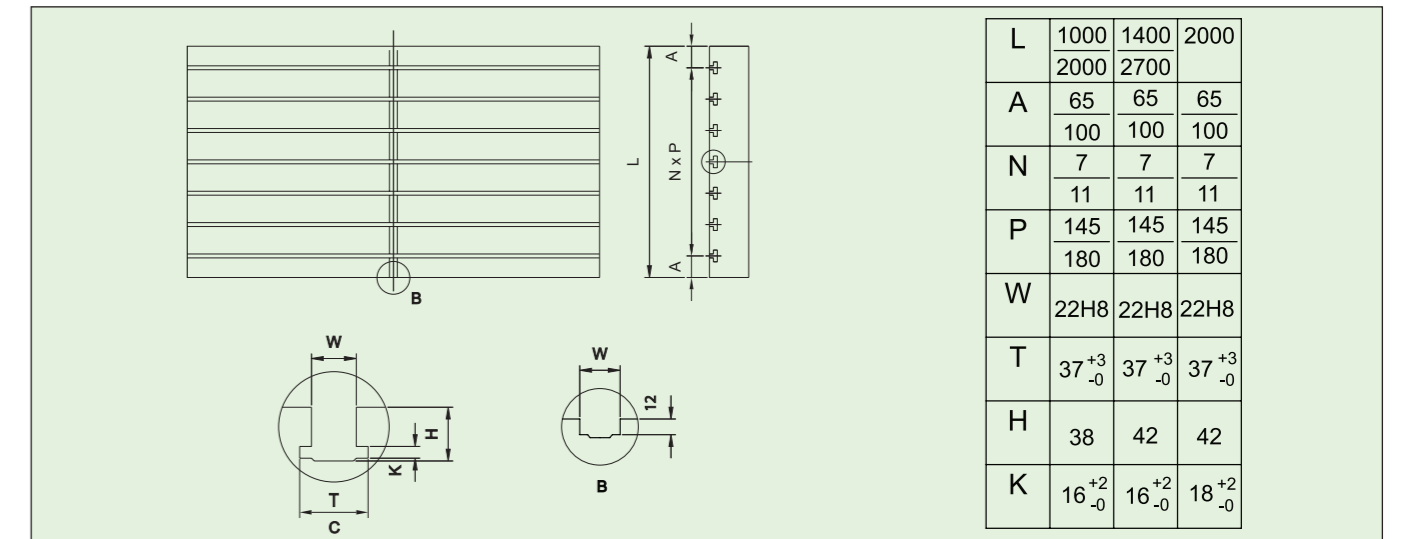

刀柄(BT50)，拉刀螺栓 Tool Shank (BT-50), Pull-Stud

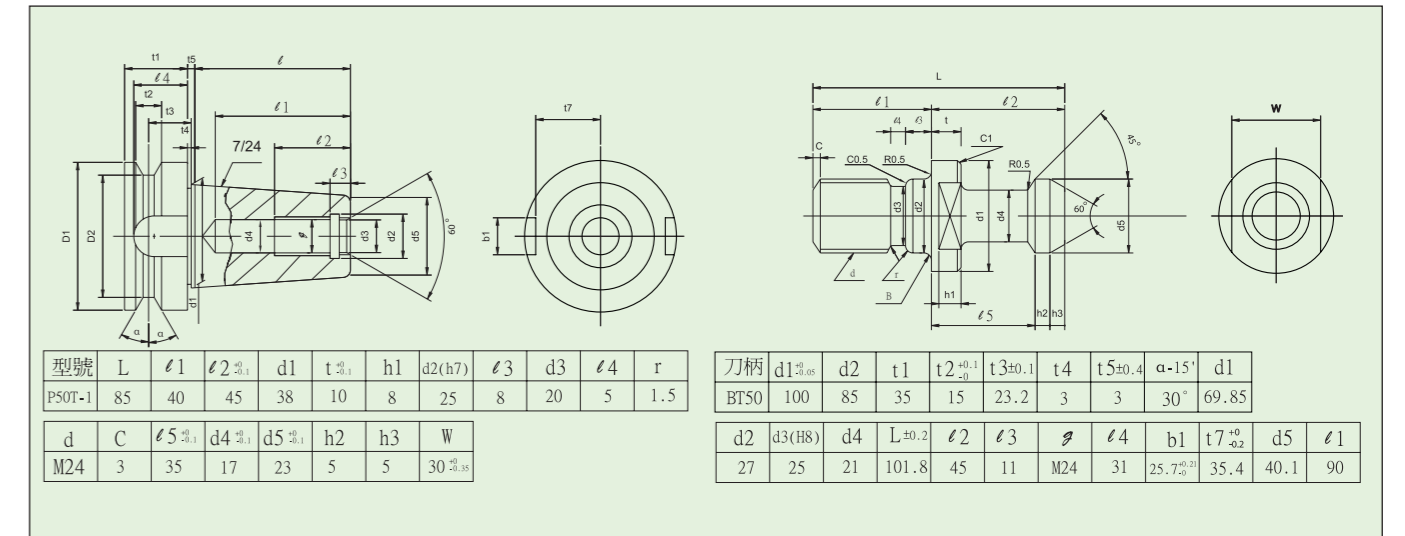

* 由於不斷的研究發展改進，規格設計如有變更，恕不另行通知。
Due to constant researches, development, improvement, all specifications and designs are subject to change without notice.

標準附件	Standard Accessories	
基礎螺絲及安裝零件	1組	Anchor Bolts & Setting Components 1 Set
工具及工具箱	1組	Tools And Tool Box 1 Set
床台護蓋	1組	Work Table Cover 1 Set
主軸防護罩	1組	Spindle Cover 1 Set
自動潤滑系統	1組	Auto Lubrication System 1 Set
主軸油溫冷卻裝置	1組	Spindle Oil Cooling Machine 1 Set
ZF齒輪箱	1組	ZF Gear Box 1 Set
電控箱溫控裝置	1組	Electric Cabinet Thermal Control 1 Set
主軸吹氣除屑裝置	1組	Spindle Chip Blowing Device 1 Set
工作燈	1組	Work Lamp 1 Set
警示燈	1組	Flash Light 1 Set
選擇附件	Optional Accessories	
切削油裝置	1組	Cutting Oil Equipment 1 Set
ATC裝置40把	1組	Automatic Tool Changer 40 Pcs 1 Set
對刀儀	1組	Tool Setting System 1 Set
鐵屑回收裝置	1組	Chip Conveyor 1 Set
半罩式防濺護罩	1組	Partial Splash Guard 1 Set