



TWIN HEAD MILLING MACHINE

CBDM series



張圳雄企業股份有限公司
CHANG CHUN HSIUNG ENTERPRISE CO., LTD.

公司（台灣）：台中市太平區永義路113號
工廠（台灣）：台中市太平區永義路117巷1號
113, YUNG YI ROAD, TAIPING, DIST, TAICHUNG
CITY, TAIWAN

TEL : 886-4-22733363 • 886-4-22733665

FAX : 886-4-22733369

E-mail : changccb@ms36.hinet.net

<http://www.topchang.com.tw>

High Accuracy . High Quality . High Rigidity

CBDM-1200

- 全自動操作
 - 一次設定，四個側面銑削加工
 - 適合中大型工件尺寸
 - 高效率加工
- Fully automatic operation
 - 4 sides cutting setting
 - Ideal for middle and big square molds
 - High efficiency

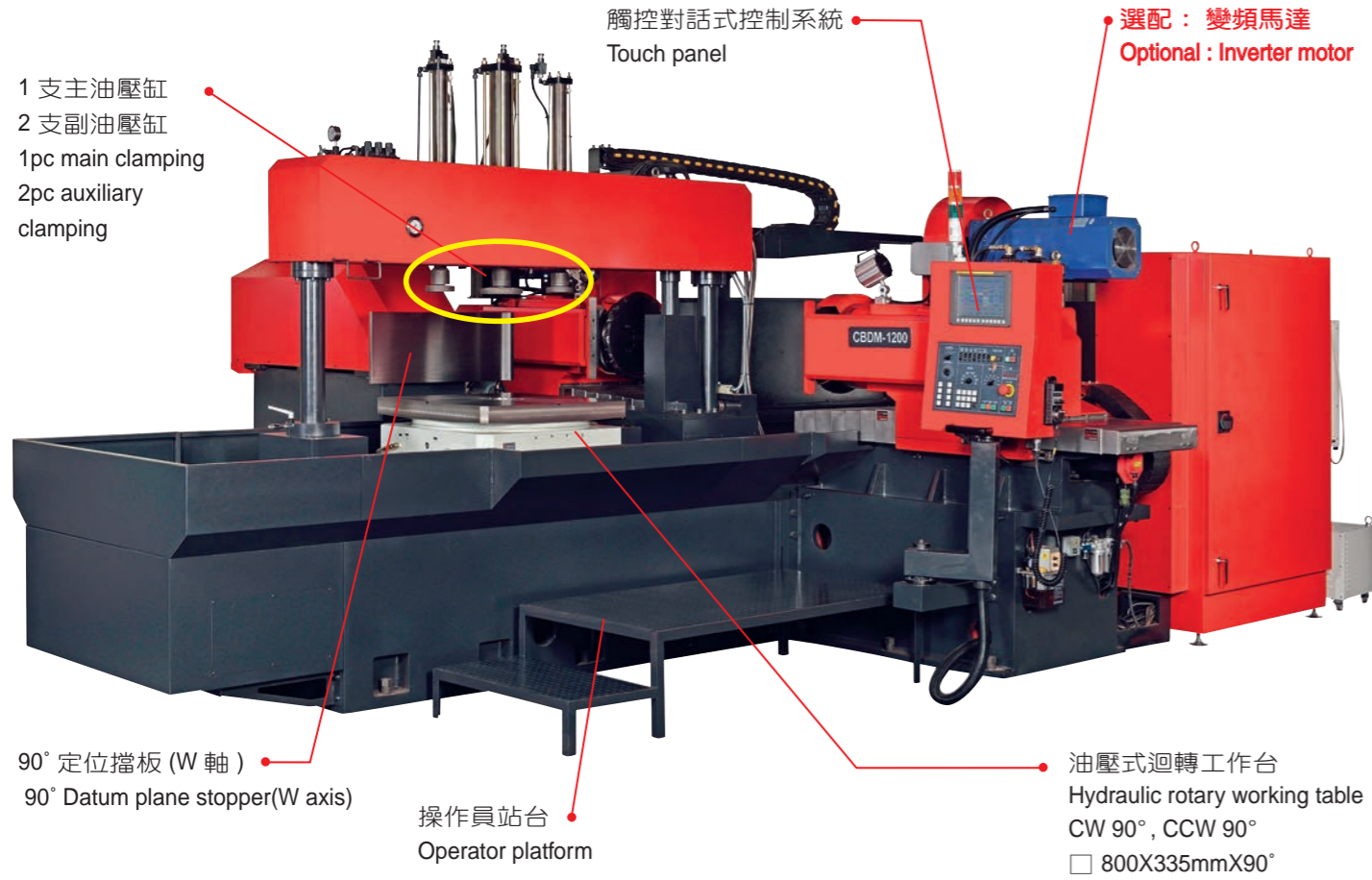

CBDM-600

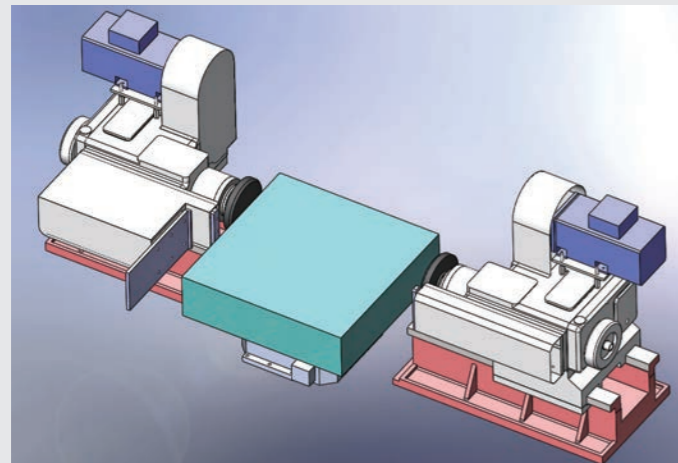
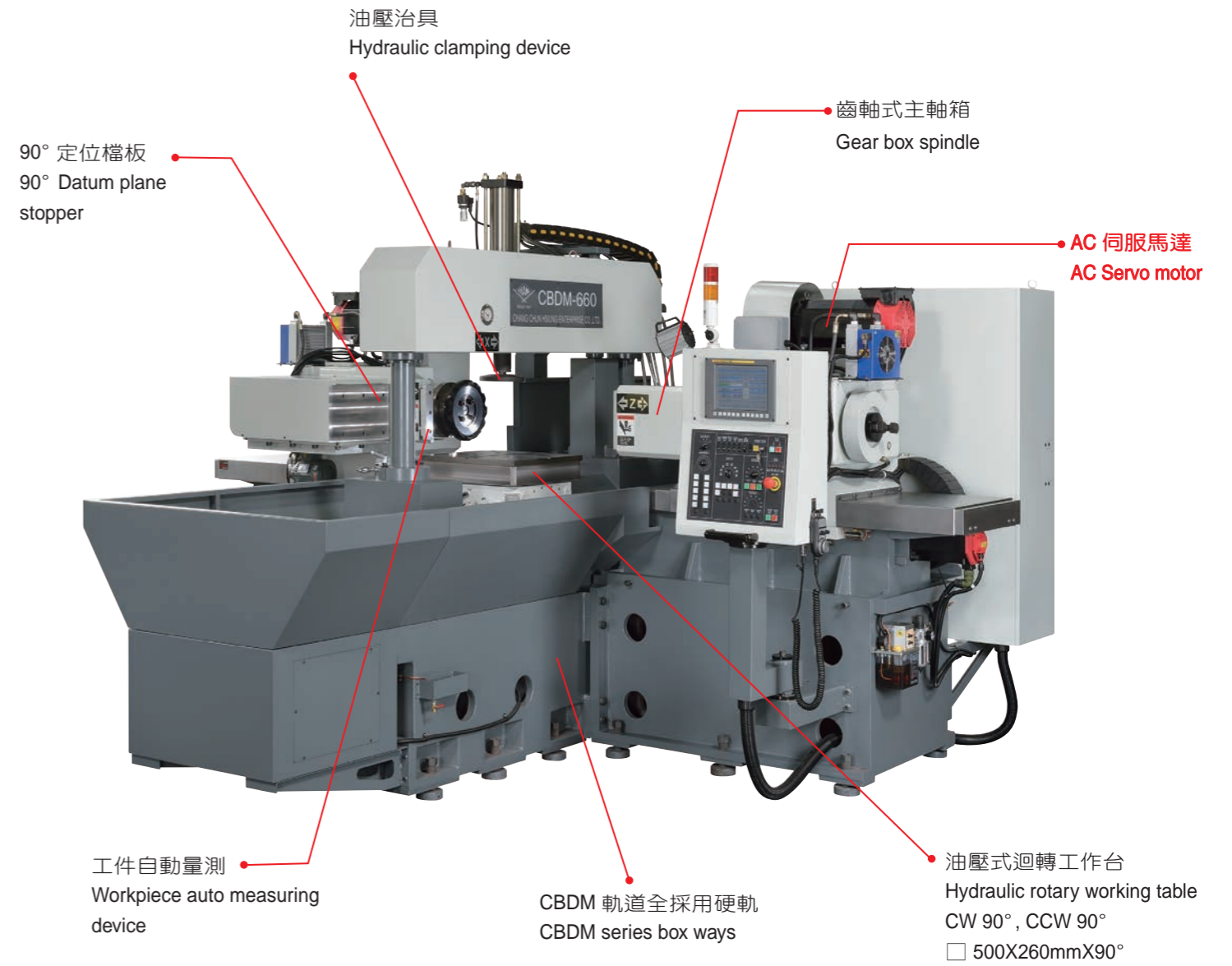

CBDM-1200

最小加工尺寸 (Min workpiece size)
(L×W) 500×500mm
最大加工尺寸 (Max workpiece size)
(L×W) 1200×1200mm

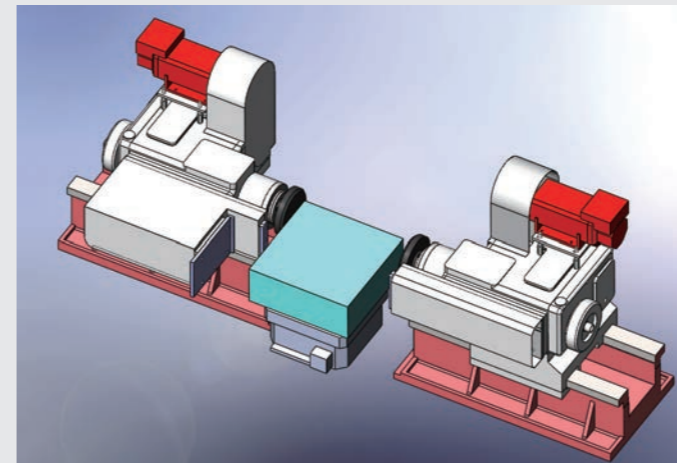

CBDM-600

最小加工尺寸 (Min workpiece size)
(L×W) 150×150mm
最大加工尺寸 (Max workpiece size)
(L×W) 600×600mm

高生產力

主軸配置伺服馬達，搭配齒輪式主軸箱經齒輪減速比可傳輸大扭力，獲得最佳切削功率。

主軸箱加裝風冷式散熱裝置，可降低溫升並保持精度。

- CBDM-800 / CBDM-1000
主軸馬達可選用搭配變頻馬達
- CBDM-800 / CBDM-1000
可選用 BT-60 主軸

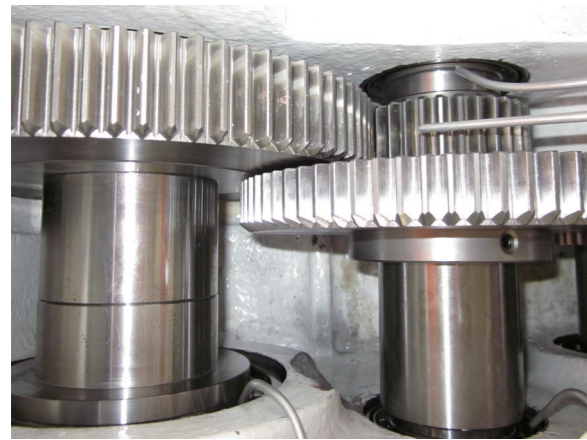

High productivity

Spindles equipped with AC servo spindle motor. Gears through reduce ration get high torque.

Spindles equipped with cooling fan for reducing temperature and keeping accuracy.

- CBDM-800 / CBDM-1000
spindle motor can be changed to inverter motor
- CBDM-800 / CBDM-1000
spindle can be changed to BT-60

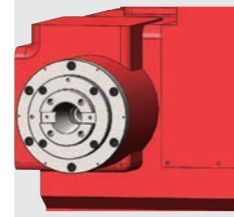

BT-50 主軸 / BT-50 spindle

- 刀盤最大可選用直徑 305mm
- Max. cutter diameter 305mm
- 變頻馬達最大可選用 20HP
- Max. inverter motor 20HP



BT-60 主軸 / BT-60 spindle

- 刀盤最大可選用直徑 425mm
- Max. cutter diameter 425mm
- 變頻馬達最大可選用 40HP
- Max. inverter motor 40HP

方型硬軌

CBDM 系列滑道全採用硬軌。高剛性鑄件結構讓機械本體變形量、誤差量達到最小。

CBDM machine slideways are all adopt box way.

High rigid casting structures give you the best machine durability and reduce deformations.

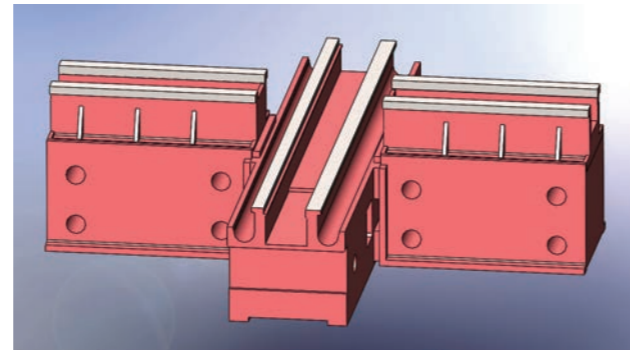

工件自動量測

以精密儀器自動量測並進行判讀，以降低人為失誤、快速安全。

此外，並可進行不平整工件的量測及精切削。

Workpiece auto measuring device

Touch sensors will auto measuring workpiece and execute Error Checking and Correction for users.

The device can be used on irregular surface measuring and finishing cutting.

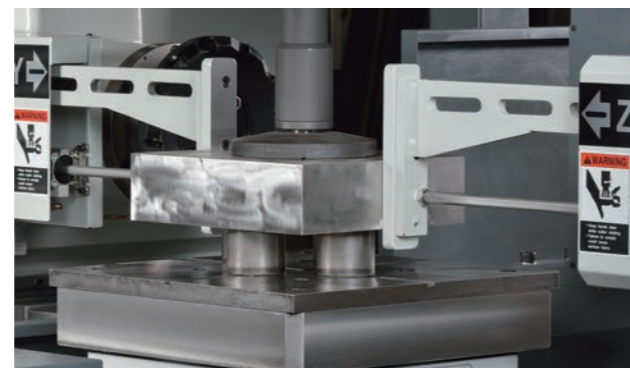

90° 定位檔板

此裝置可方便操作員迅速將工件放至迴轉工作台中心，節省上下料時間。

90° Datum plane stopper

It is very convenient and save time for users putting workpieces on the central of rotary working table.

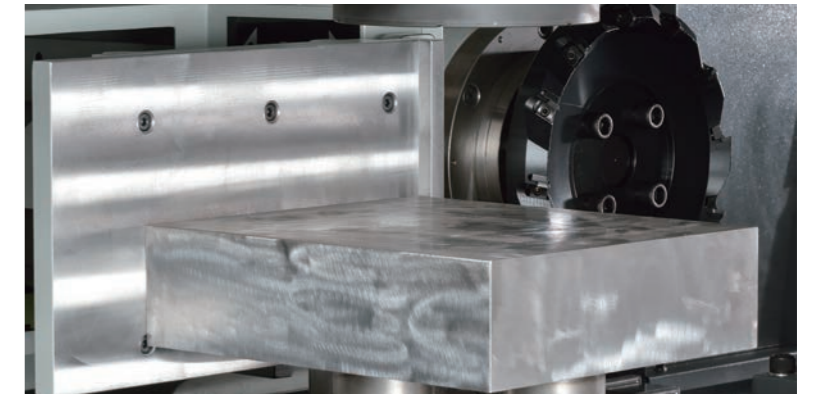

油壓治具

- CBDM-600 配置 1 支主油壓缸
- CBDM-800 / CBDM-1000 / CBDM-1200 配置 1 支主油壓缸及 2 支副油壓缸

Hydraulic clamping fixture

We adopt hydraulic fixture to clamp and unclamp workpieces.

- CBDM-600 are equipped with single clamping fixture.
- CBDM-800 / CBDM-1000 / CBDM-1200 are equipped with 3 pcs clamping fixture, 1 pc main clamping 2 pcs auxiliary clamping.

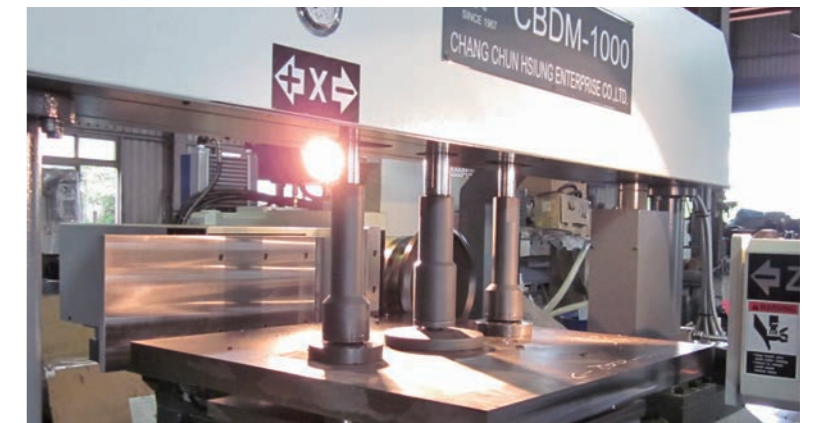
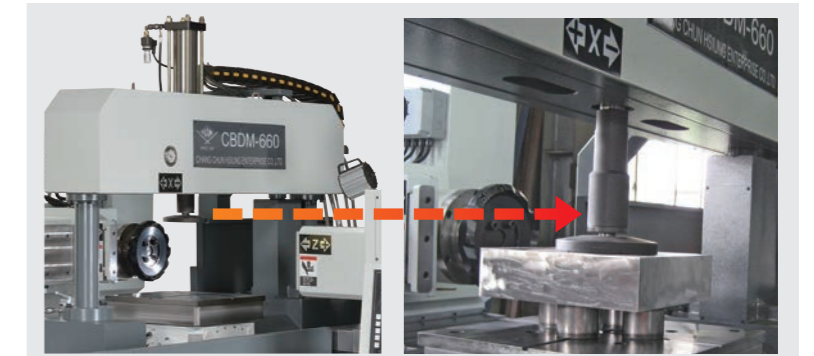

油壓式迴轉工作台，正轉 90°，反轉 90°

迴轉工作台上額外附加一塊護盤，以保護迴轉工作台面不受損耗。

迴轉工作台內部採用齒式聯結器，以確保分度精確。

Hydraulic rotary working table, CW 90°, CCW 90°

We add extra protection plate on the rotary table for reduce surface damages of rotary working table.

Hydraulic rotary working table inside adopts hirth coupling for position, powerful clamping design, allow heavy cutting.

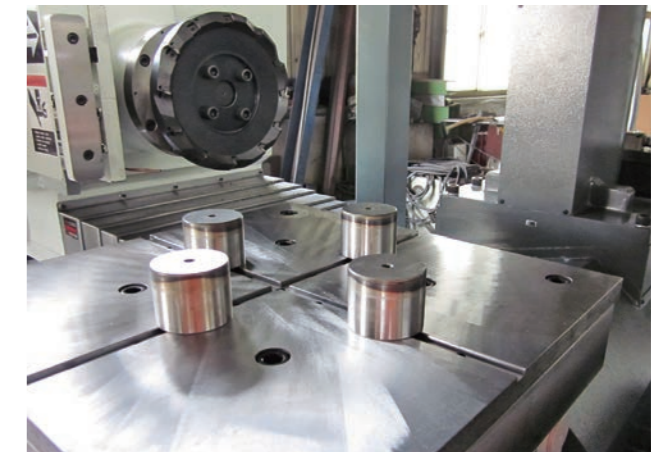

觸控對話式控制系統

人性化的操作介面，簡單易學，所有加工動作均已顯示在銀幕上。

搭配精切削功能，可得更精準的尺寸。

Touch panel

User-friendly interface and easy learning. Processing functions are all set in the controller.

Additional cutting function is suitable for finishing cutting and more accuracy sizes.

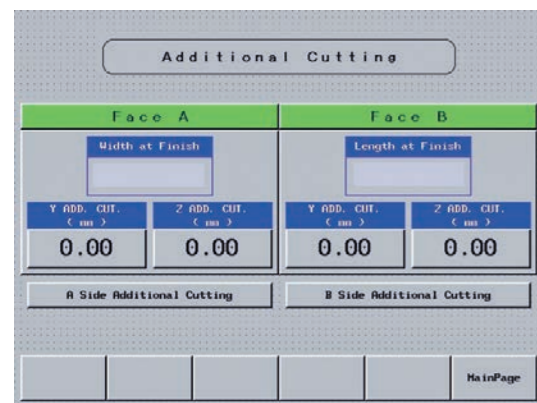
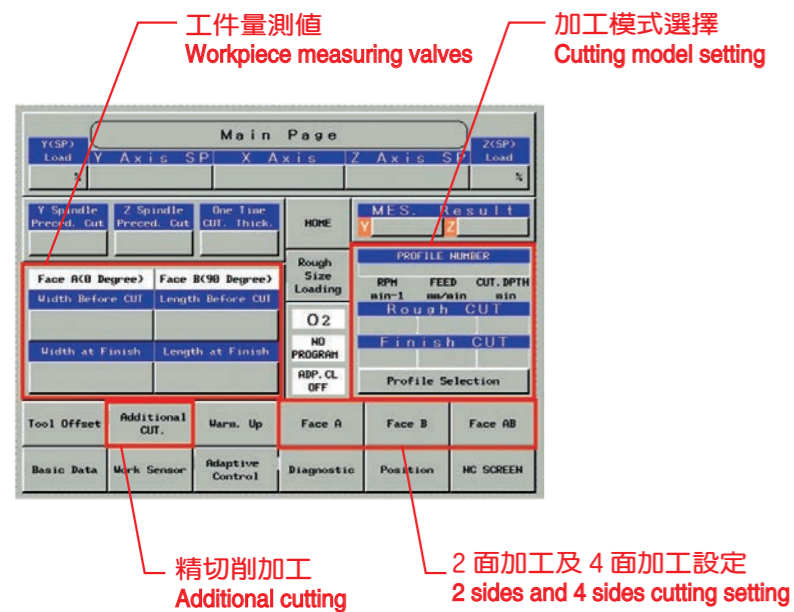

精切削加工
Additional cutting

	單位 unit	CBDM-600	CBDM-800				CBDM-1000				CBDM-1200	
工作台行程 (X 軸) Table travel (X axis)	mm	1030	1300				1500				1700	
主軸行程 (Y / Z 軸) Spindle head (Y / Z axis)	mm	290	360		370		445		415		430	
主軸中心至工作台表面距離 Distance from spindle center to table surface	mm	447	462	490	490	490	565	490	490	565	565	
主軸鼻端至工作台中心距離 Distance from spindle nose to table center	mm	120~410		155~515		155~525		205~650		205~620		
兩主軸間距離 Distance between spindles	mm	240~820		310~1030		310~1050		410~1300		410~1240		
工件尺寸範圍 Workpiece size (L / W)	mm	□ 150 □ 600		□ 250 □ 800				□ 350 □ 1000				□ 500 □ 1200
刀盤有效直徑 Effective diameter of face cutter	mm	250	305	250	305	305	425	250	305	305	425	
工件最大厚度 Workpiece size (H)	mm	230	290	230	290	290	400	230	290	290	400	
工作台尺寸 (LxW) Working table size	mm	1600x520		1900x520				2200x520				2500x700
迴轉工作台尺寸 Size of rotary working table	mm	□ 500x260x90°		□ 500x260x90°				□ 600x285x90°				□ 800x335x90°
迴轉工作台最大載重 Rotary working table loading	kg	850		2000				3200				4500
主軸錐度 Spindle taper	JSB6101	BT-50		BT-50		BT-60		BT-50		BT-60		
主軸轉速 Spindle speed	rpm	70~1000		70~1000	70~550	70~450	70~450	70~730	70~550	70~450	70~450	
主軸段數 Spindle change		無段 Stepless										
主軸馬達 Spindle motor	Kw	AC servo 7.5kw		AC servo 7.5kw		Inverter motor 15kw		Inverter motor 15kw		Inverter motor 22.5kw		
速度 Spindle of feed	mm/min	10~3000										
進給速度 (X 軸) Rapid feed (X axis)	mm/min	6000										
進給速度 (YZ 軸) Rapid feed (YZ axis)	mm/min	5000										
馬達 Motor	kw	4		7								
快送 (X 軸) Feed (X axis)												
快送 (YZ 軸) Feed (YZ axis)				4								
油壓馬達 Hydraulic motor	kw			5								
潤滑幫浦 Lubrication pump	Kw			1.5								
機械重量 Machine weight	kg	13500		15650				16500				19000
機械佔用面積 (L×W×H) Required floor space	mm	4350x4100x2550		4750x4600x2650				5000x4600x2650				5500x4700x2650
NC 裝置 Controller		Fanuc Touch panel controller										

標準附件	Standard accessories
基礎螺絲及安裝零件	1 組 Foundation screws & pads
工具及工具箱	1 組 Tools and tool box
迴轉工作台	1 組 Hydraulic rotary working table
油壓系統	1 組 Hydraulic system
油壓治具	1 組 Hydraulic clamping device
X 軸防塵蓋	2 組 X axis dust cover
Y、Z 軸防塵蓋	4 組 Y、Z axis dust cover
X 軸兩側鐵屑螺桿輸送機	2 組 Screw type chip conveyor
半罩式鈹金	1 組 Half splash guard
工作燈和警示燈	2 組 Working light & Warning light
電器箱冷卻機	1 組 Air conditioner of electric cabinet
主軸吹氣裝置	2 組 Air blow device
定位擋板	1 組 Datum plane stopper
工件量測	2 組 Workpiece auto measure device
發那科 Oi-MF 觸控銀幕	1 組 Fanuc Oi-MF touch panel

選擇附件	Optional accessories
刀盤	2 組 Face cutter
刀片	Tips
CE 規格	CE specification